

## ART. 680

VALVOLA A SFERA A PASSAGGIO TOTALE ATTACCHI  
F.F. CON MANIGLIA A LEVA FILETTATURA EN 10226

BALL VALVE FULL BORE F.F. WITH LEVER HANDLE  
THREAD EN 10226

heavyvalve

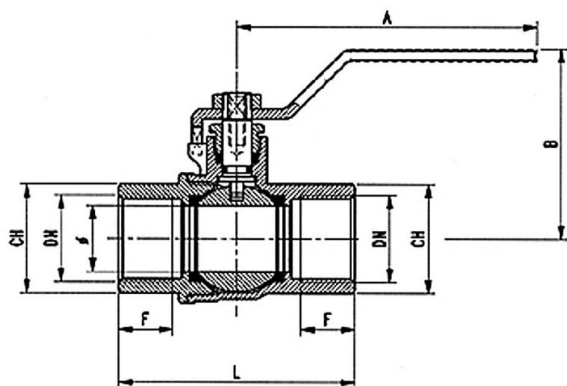

### IMPIEGHI - USES

Airaga Rubinetterie S.P.A. produce e collauda le valvole a sfera art. 680 adottando un sistema di qualità secondo le norme UNI EN ISO 9001:2015. Vengono utilizzate principalmente in impianti idraulici domestici e commerciali, applicazioni industriali ed agricole, impianti di riscaldamento, idrici, igienico-sanitari, aria compressa, reti di distribuzione olii, benzine, vapore saturo, servizi di acqua calda, linee di condensa, petrolio e altri idrocarburi, generalmente con ogni fluido compatibile non corrosivo, a media ed alta pressione.

Airaga Rubinetterie spa produces and tests ball valves range 680 according to a quality system UNI EN ISO 9001:2015. They are mainly used in: domestic and commercial hydraulic plants, agricultural and industrial systems, heating systems, waterworks, compressed air, oil distribution networks, gasoline, saturated steam, hot water, condensate lines, oil and other hydrocarbons, generally with every other compatible non corrosive fluid, with medium and high pressure

### MATERIALI E CARATTERISTICHE – MATERIALS AND FEATURES

**Corpo e maniccotto:** stampati a caldo da barra EN12165 CW617N fino al 3", 4" fusi in ottone EN1982, nichelati.

**Premistoppa e asta di comando:** lavorati da barra EN12164 CW617N.

**Sfera:** 1/4" e 3/8" tornita da barra EN12164 CW617N, dal 1/2" al 1"1/4 stampata da barra EN 12165 CW617N, dal 1"1/2 al 4" fusa in ottone EN1982, diamantata e cromata a spessore.

**O-ring asta:** EPDM 4270 per le misure dal 1/2" al 2".

**Guarnizioni di tenuta sfera:** P.T.F.E.

**Guarnizione asta:** P.T.F.E.

**Leva di manovra:** acciaio DD11 EN10111, zincata e rivestita PVC.

**Dado:** UNI 5589-65 - acciaio zincato.

**Attacchi filettati:** filettature EN 10226 - A richiesta: ISO 228/1 (Cilindrica) - ANSI B.1.20.1 (NPT).

**Sigillante per filettature:** adesivo anaerobico tipo "Loctite".

**Trattamento esterno valvola:** superficie nichelata brillante.

**Body and sleeve:** hot moulded from EN12165 CW617N bar until 3", 4" melted in brass EN1982, nickel plated.

**Gland and stem:** worked from EN12164 CW617N bar.

**Ball:** 1/4" and 3/8" turned from EN12164 CW617N bar, from 1/2" to 1"1/4 hot moulded from EN12165 CW617N bar, from 1"1/2 to 4" melted in brass EN1982, diamond and chrome plated.

**O-ring stem:** EPDM 4270 for sizes from 1/2" to 2".

**Ball gaskets:** P.T.F.E.

**Stem gasket:** P.T.F.E.

**Operating lever:** steel DD11 EN10111, galvanized and coated with PVC.

**Nut:** UNI 5589-65 - galvanized steel.

**Threaded connections:** EN 10226 - On request: ISO 228/1 (Cylindric), ANSI B.1.20.1 (NPT) threads.

**Seal for threads:** "Loctite" type anaerobic adhesive.

**External treatment:** brilliant, nickel plated surface.

### CONDIZIONI DI ESERCIZIO – WORKING CONDITIONS

**Temperatura di esercizio:** limite di servizio da -20 °C a +120 °C.

**Working temperature:** service limit from -20 °C to +120 °C.

**Pressione massima di esercizio | Maximum working pressure**

DN	PN
1/4" - 3/8" - 1/2"	60
3/4" - 1"	40
1"1/4	25
1"1/2 - 2" - 2"1/2 - 3" - 4"	16

ART.	0680/02	0680/03	0680/04	0680/05	0680/06	0680/07	0680/08	0680/09	0680/10	0680/11	0680/13
<b>DN e pass. mm</b>	1/4" (10)	3/8" (10)	1/2" (15)	3/4" (20)	1" (25)	1"1/4 (32)	1"1/2 (40)	2" (50)	2"1/2 (60)	3" (74)	4" (94)
<b>L</b>	46,5	46,5	62	71	81,5	92	102	126	138	161,5	181
<b>B</b>	40,5	40,5	53,5	57,5	66,5	72	83,5	90	116	132	150
<b>F</b>	10	10	15	16,3	19,1	21,4	21,4	26	26	27	28
<b>CH</b>	21	21	26	31	38	48	55	68	85	98	123
<b>A</b>	80	80	90	90	125	125	150	150	203	280	280
<b>Peso (Weight) g.</b>	155	150	270	365	605	880	1340	1980	3095	4890	8000